

Digital pressure gauge Model CPG500

WIKA data sheet CT 09.01

Applications

- Calibration service companies and service industry
- Measurement and control laboratories
- Quality assurance
- Easy on-site calibration

Special features

- Measuring ranges from -1 ... +20 bar to 0 ... 1,000 bar
- Accuracy: 0.25 % (incl. calibration certificate)
- Robust case with protective rubber cap
- Simple operation using four buttons
- Complete service cases incl. pressure generation available

Description

General

The model CPG500 digital pressure gauge enables the measurement and display of pressure values in a single instrument.

The accuracy of digital measurement technology and the simplicity of an analogue gauge are combined in this instrument.

Accuracy

The CPG500 offers an accuracy of 0.25 % of the full scale value in four pressure ranges. Readings can be displayed in one of five standard units.

Sampling rate

With a measuring rate of 100 measurements per second, the CPG500 features a very high measuring rate. With this, fast pressure peaks and drops in pressure can be detected. The bargraph display and drag pointer function integrated into the display, as well as retrievable MIN/MAX peak values, enable effective analysis of the measuring point.



Digital pressure gauge CPG500

Properties

In order to prolong the battery life, the CPG500 features an automatic switch-off function.

With the ZERO function, the display value can be zeroed with the simple press of a button.

An activatable filter function stabilises pressures which fluctuate strongly, and enables the pressure value to be read easily.

Complete test and service cases

For maintenance and service applications, various service case systems are available. Service cases with pneumatic or hydraulic pressure generation are available.

Certified accuracy

For each digital pressure gauge, the accuracy is certified by a factory calibration certificate which accompanies the instrument. On request, we are also pleased to provide a DKD/DAkkS calibration certificate for the instrument from our own DKD/DAkkS laboratory.

Specifications

Model CPG500

Sensor technology

Measuring range	bar	-1 ... +20	-1 ... +40	0 ... 700	0 ... 1,000
Overpressure limit	bar	50	80	1,200	1,500
Burst pressure	bar	250	400	2,400	3,000
Resolution	bar	0.01		0.1	
Pressure connection		G ¼		G ½	
Accuracy		0.25 % FS ± 1 digit			

Base instrument

Indicator

Display	4 ½ digit, bargraph with drag pointer function, illuminated
Dimensions	50 x 34 mm
Digit height	15 mm
Pressure units	bar, mbar, psi, MPa, kPa

Function

Measuring rate	10 ms
Memory	MIN/MAX
Autopower	Selectable
Zero function	Zero point adjustment
Reset	Delete MIN/MAX value

Material

Wetted parts ¹⁾	Stainless steel with sealing NBR
Case	Die-cast zinc with TPE protective rubber cap

Voltage supply

Power supply	2 x 1.5 V AA batteries
Battery life	approx. 1,500 hrs.
Battery status indication	Icon in display

Permissible ambient conditions

Operating temperature	-10 ... +50 °C
Medium temperature	-20 ... +80 °C
Storage temperature	-20 ... +60 °C
Relative humidity	< 85 % r.H. (non-condensing)

Case

Rotatability	> 270 °
Dimensions	79 x 79 x 33 mm
Ingress protection	IP 67
Weight	approx. 400 g

1) Only for use with safe media per directive 67/548/EEC (article 2, paragraph 2).

Approvals and certificates

CE conformity

EMC directive	2004/108/EC, EN 61000-6-3 emissions for commercial and light industrial environments and EN 61000-6-2 interference immunity for industrial environments
---------------	---

Certificate

Calibration	3.1 calibration certificate per DIN EN 10204 optional: DKD/DAkkS calibration certificate
-------------	---

Dimensions in mm

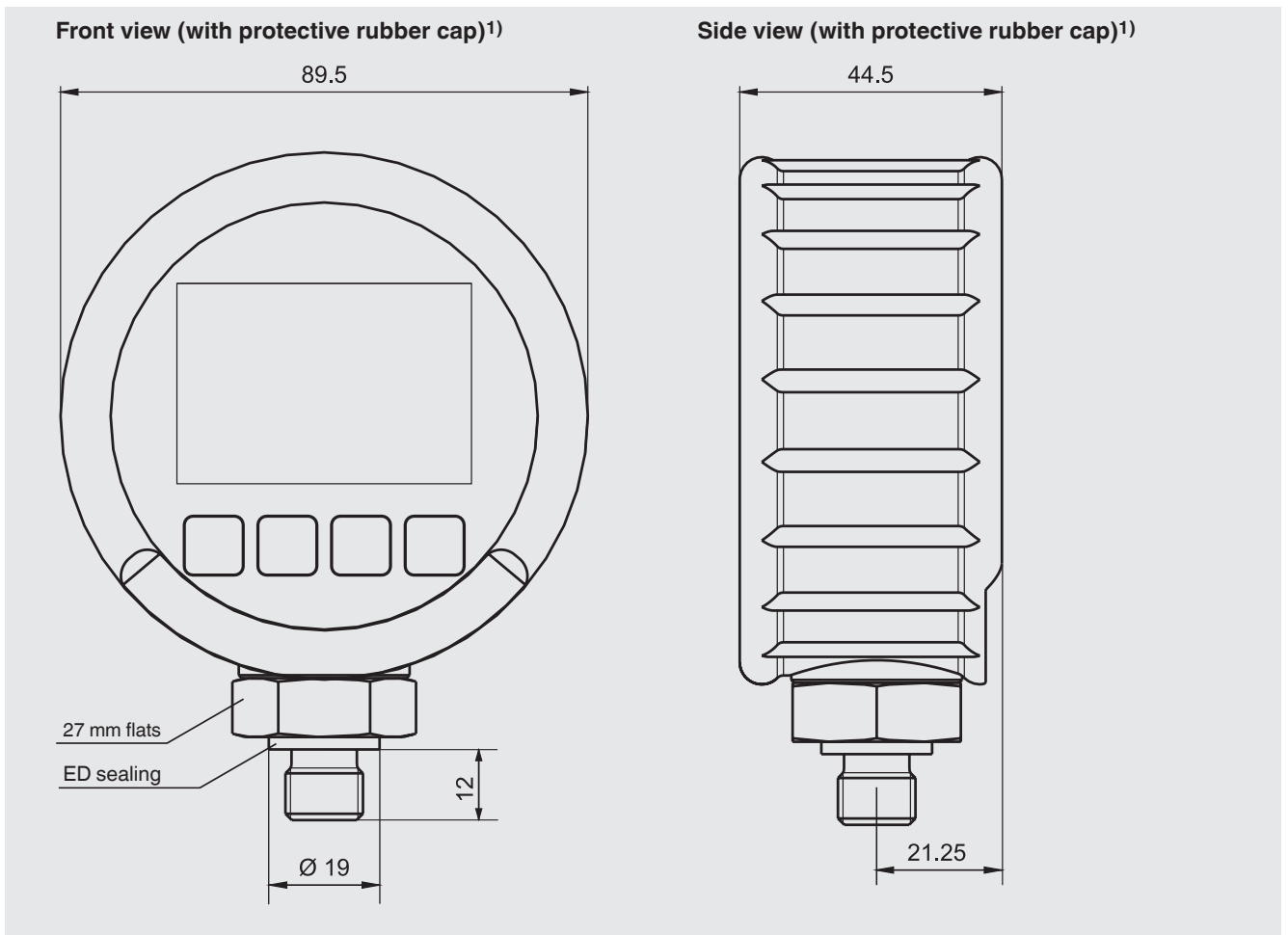

1) Drawing with G 1/4 pressure connection

Front foil of the model CPG500 digital pressure gauge



- 1) Bargraph indicates the current pressure graphically
- 2) Currently-set unit
- 3) Display of the measuring range or the MIN/MAX value
- 4) Clear the MIN/MAX values
Confirmation function in the menu
- 5) Hold down to access the menu
Zero point adjustment carried out by simply pressing
- 6) Display value (3) changed to MIN/MAX or full scale
- 7) Switch digital pressure gauge on/off
Switch on backlighting
- 8) Battery status
- 9) Pressure display

Complete test and service cases



Calibration case with model CPG500 digital pressure gauge and model CPP40 hand test pump, for pressures -0.95 ... +40 bar, consisting of:

- Plastic service case with foam insert
- Model CPG500 digital pressure gauge
- Model CPP40 pneumatic hand test pump; -0.95 ... +40 bar

Basic version incl. pneumatic pressure generation

Available measuring ranges: see specifications on page 3.



Calibration case with model CPG500 digital pressure gauge and model CPP700-H or CPP1000-H hand test pumps, for pressures 0 ... 700 bar or 0 ... 1,000 bar, consisting of:

- Plastic service case with foam insert
- Model CPG500 digital pressure gauge
- Model CPP700-H or CPP1000-H hydraulic hand test pumps, 0 ... 700 bar or 0 ... 1,000 bar

Basic version incl. hydraulic pressure generation

Available measuring ranges: see specifications on page 3.

Recommended pressure generation

Model CPP40 pneumatic hand test pump

Pressure range: -0.95 ... +40 bar



Model CPP700-H or model CPP1000-H hydraulic hand test pumps

Pressure range: 0 ... 700 bar or 0 ... 1,000 bar

For further specifications, see data sheet CT 91.07.

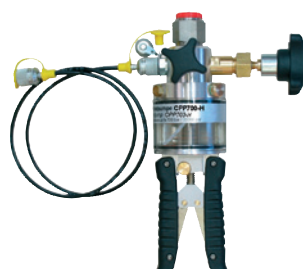

Scope of delivery

- Digital pressure gauge model CPG500
- Operating instructions
- 3.1 calibration certificate per DIN EN 10204
- 2 x AA batteries
- Protective rubber cap for case

Option

- DKD/DAkkS certified accuracy

Accessories

Connection adapters

- Various pressure adapters

Pressure generation

- Pneumatic test pumps
- Hydraulic test pumps

Test cases

- Various calibration cases incl. pressure generation

Ordering information

Model / Unit / Measuring range / Process connection / Test pump / Transport case / Type of certificate / Additional ordering information

© 2011 WIKA Alexander Wiegand SE & Co. KG, all rights reserved.
The specifications given in this document represent the state of engineering at the time of publishing.
We reserve the right to make modifications to the specifications and materials.

WIKA data sheet CT 09.01 · 12/2011

Page 5 of 5



WIKA Alexander Wiegand SE & Co. KG
Alexander-Wiegand-Straße 30
63911 Klingenberg/Germany
Tel. (+49) 9372/132-0
Fax (+49) 9372/132-406
E-mail info@wika.de
www.wika.de