

## Threaded Resistance Thermometers Model TR10-D, Miniature Design

WIKA Data Sheet TE 60.04



### Applications

- Machine building, plant and tank construction
- Power transmission engineering
- Air-conditioning and refrigeration systems

### Special Features

- Application ranges from -200 °C to +600 °C
- Compact design
- Universal application
- Direct installation in the process
- Explosion-protected versions Ex-i, Ex-n and NAMUR NE24



**Threaded Resistance Thermometer, Miniature Design  
Model TR10-D**

### Description

This series of resistance thermometers is designed for the measurement of liquid or gaseous media at low and medium pressures.

The resistance thermometer is screwed directly into the process and the terminals in the connection head are used for electrical connection (protected against water splashes). For the measuring inserts, they are available in two variants, depending upon the application. The choice is between a replaceable, spring-loaded miniature measuring insert and a non-replaceable design.

Insertion length, process connection and sensor can be selected for the respective application from the order information sheet.

Intrinsically safe designs are available for applications in hazardous areas.

The models of the TR10-D series are provided with a type examination certificate for "intrinsically safe" protection in accordance with Directive 94/9/EC (ATEX) for gases and dust. Manufacturer's Declarations in accordance with NAMUR NE24 are also available.

## Sensor

The sensor is located in the tip of the measuring insert.

### Sensor method of connection

- 2-wire The lead resistance of the measuring insert compounds the error.
- 3-wire With a cable length of approx. 30 m or longer measuring deviations can occur.
- 4-wire The inner lead resistance of the connecting wires is negligible.

### Sensor limiting error

- Class B per DIN EN 60 751
- Class A per DIN EN 60 751
- 1/3 DIN B at 0 °C

It makes no sense to combine 2-wire connection with class A or 2-wire connection with 1/3 DIN B, because the lead resistance of the cable overrides the higher sensor accuracy.

### Basic values and limiting errors

Basic values and limiting errors for the platinum measurement resistances are laid down in DIN EN 60 751.

The nominal value of Pt 100 sensors is 100 Ω at 0 °C.

The temperature coefficient  $\alpha$  can be stated simply to be between 0 °C and 100 °C with:

$$\alpha = 3.85 \cdot 10^{-3} \text{ }^{\circ}\text{C}^{-1}$$

The relationship between the temperature and the electrical resistance is characterised by polynomials which are defined in DIN EN 60 751. Furthermore, this standard lays down the basic values in °C stages.

Class	Limiting error in °C
A	$0.15 + 0.002 \cdot  t $ <sup>1)</sup>
B	$0.3 + 0.005 \cdot  t $

1) |t| is the value of the temperature in °C without consideration of the sign

Temperature (ITS 90) °C	Basic value Ω	Limiting error DIN EN 60 751			
		Class A		Class B	
°C	Ω	°C	Ω	°C	Ω
-200	18.52	± 0.55	± 0.24	± 1.3	± 0.56
-100	60.26	± 0.35	± 0.14	± 0.8	± 0.32
-50	80.31	± 0.25	± 0.10	± 0.55	± 0.22
0	100	± 0.15	± 0.06	± 0.3	± 0.12
50	119.40	± 0.25	± 0.10	± 0.55	± 0.21
100	138.51	± 0.35	± 0.13	± 0.8	± 0.30
200	175.86	± 0.55	± 0.2	± 1.3	± 0.48
300	212.05	± 0.75	± 0.27	± 1.8	± 0.64
400	247.09	± 0.95	± 0.33	± 2.3	± 0.79
500	280.98	± 1.15	± 0.38	± 2.8	± 0.93
600	313.71	± 1.35	± 0.43	± 3.3	± 1.06

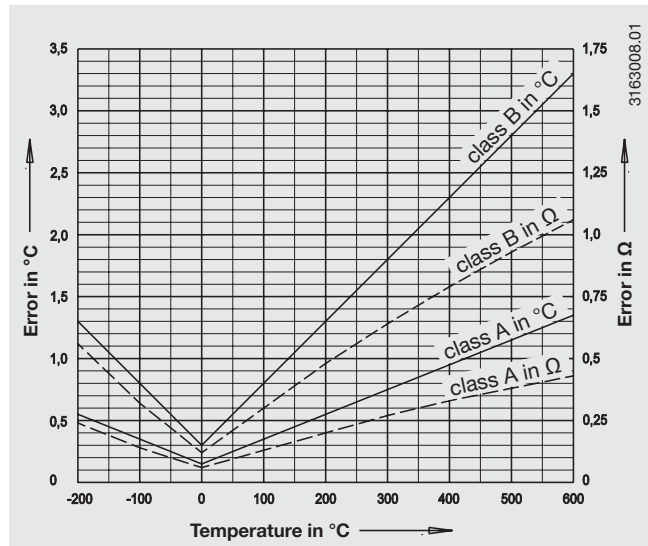

## TR10-D components

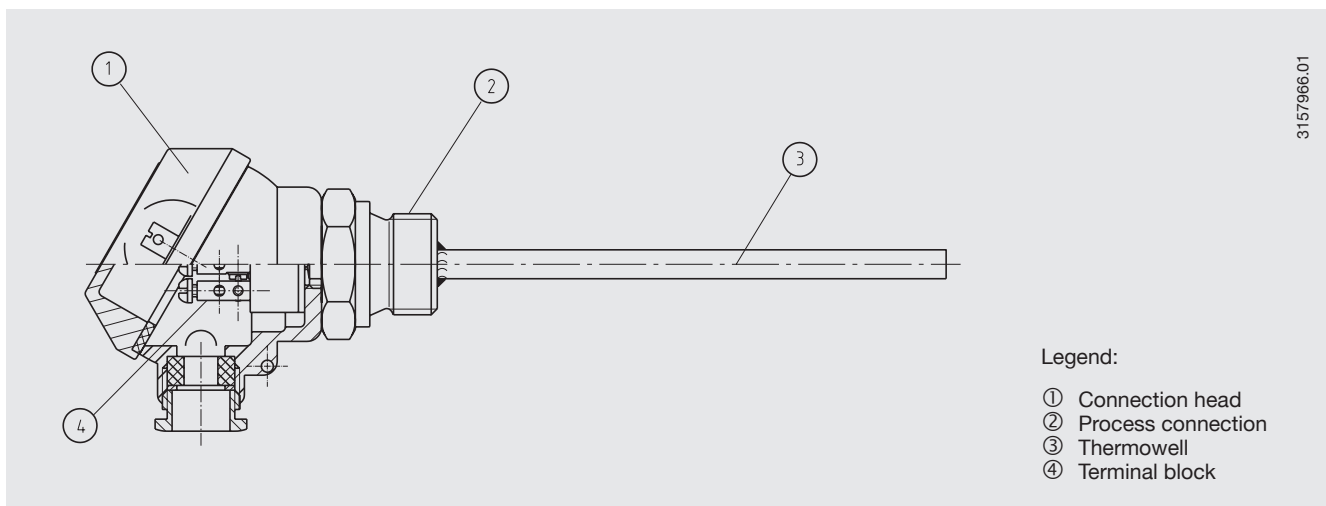

## Connection head

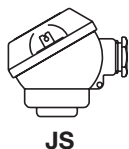

Model	Material	Cable entry	Ingress protection	Cap	Surface finish
JS	Aluminium	M16 x 1.5 <sup>1)</sup>	IP 54	Cap with 2 screws	blue, painted <sup>2)</sup>

1) Standard

2) RAL5022, polyester paint saltwater-proof

## Transmitter (option)

In the model JS connection head a model T91.20 analogue temperature transmitter can be factory-fitted. It is fitted in place of the terminal block.

The variant with temperature transmitter is not suitable for use in hazardous areas.

For further technical data on the model T91.20 temperature transmitter, please refer to WIKA data sheet TE 91.01.

## Measuring insert

### Removable design

The measuring insert can be mounted, replaceable and spring-loaded into the thermowell, in a connection head (Form J), using two screws and springs.

### Fixed design

The measuring insert is manufactured, as a tube assembly in a thermowell, as a unit, and thus cannot be replaced.

With this design, the temperature is limited to a max. of 250 °C.

## Thermowell

■ Material: Stainless steel

Thermowell Ø in mm	Insertion length $U_1$ in mm						
	50	75	100	150	160	250	400
6	x	x	x	x	x	x	x
8	-	-	x	x	x	x	x

## Permissible temperature

- Application ranges (Sensor): -50 °C ... +450 °C
- At the head: -40 °C ... +125 °C
- At the transmitter (optional): -40 °C ... +85 °C
- Storage: -40 °C ... +60 °C

## Process connection

All process connections are manufactured in stainless steel. Other materials are available on request.

The insertion length A ( $U_1$  or  $U_2$ ) can be specified to customer-specific requirements.

The neck length N ( $M_H$ ) depends on the type of process connection specified.

## Extended process connection

Connection heads, connecting lines/wires and the optional transmitter must only be used within the above-mentioned temperature ranges.

If the thermometer will operate at a temperature outside of the temperature limits, clearance between the connection head and hot or cold surfaces must be increased.

This neck length is dependent upon the intended application and generally serves as isolation or as a cooling element between the process and the connection head.

## Permanent connection

The connection is permanently fixed to the thermowell. The standard neck length is  $N (M_H) = 55 \text{ mm}$

## Compression fitting

The compression fitting enables the simple, in-situ adjustment to the required insertion length.

The self-extending nature of the compression fitting results in the smallest possible neck length, N, of around 55 mm.

Since the compression fitting is adjustable on the thermowell, the size of the insertion length, A, and the neck length, N, are stated as the values for the delivered item.

- Sealing ring material: Stainless-steel or Teflon®

Sealing rings from stainless-steel are only adjustable once, once the fitting has been loosened it can no longer be tightened to the thermowell.

Sealing rings from Teflon® can be adjusted numerous times, once the fitting has been loosened it can again be tightened to the thermowell.

- Max. temperature at the process connection 150 °C

## Double nipple

Via a two-sided threaded nipple, the thermometer can be screwed directly into the process. For this way, the permitted temperature ranges must be followed.

As a result of the parallel threads the neck length, N ( $M_H$ ), is the height of the hex nut. This is 10 mm.

For NPT threads, the length, N, includes half of the thread length, as well as the hex nut height. Thus the neck length, N ( $M_H$ ), is around 19 mm.

## Without process connection

This design is intended primarily for assembly in an already-existing compression fitting.

The neck length, N, here is only the height of the hex nut at the top of the thermowell.

N ( $M_H$ ) is always 7mm.

## Dimensions in mm

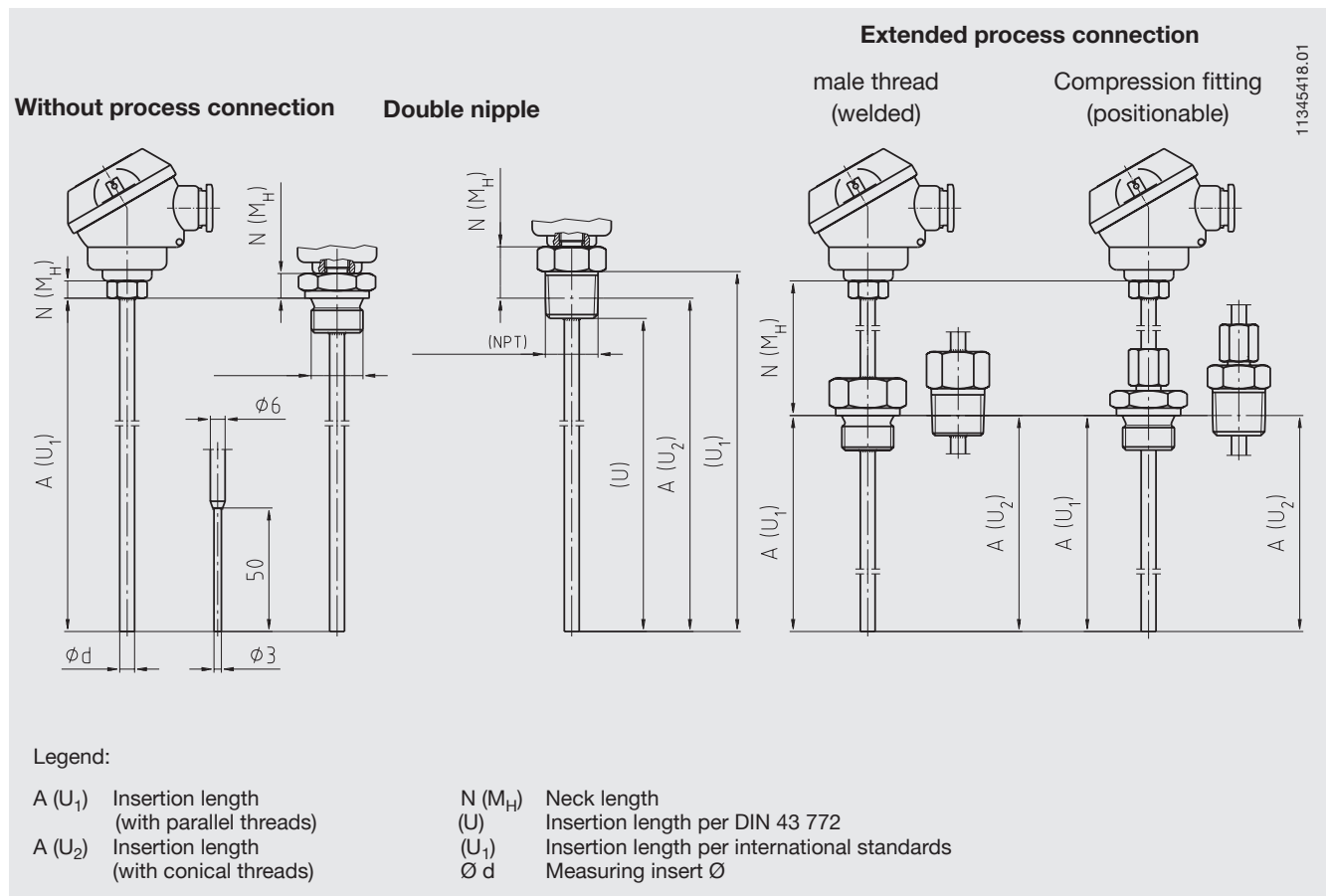

## Explosion protection (option)

Resistance thermometers of the TR10-D series are available with a type examination certificate for "intrinsically safe" ignition protection (TÜV 02 ATEX 1793 X). These thermometers comply with the requirements of directive 94/9/EC (ATEX), EEx-i, for gases and dust. Manufacturer's Declarations in accordance with NAMUR NE24 are also available.

The classification / suitability of the instrument (permissible power  $P_{max}$ , minimum neck length and permissible ambient temperature) for the respective category can be seen on the type examination certificate and in the operating instructions.

Explosion protection for model TR10-D with connection head model JS		
	Zone	Supply circuit
<b>Gases</b>	0	ia
	1	ib
	2	ib
<b>Dusts</b>	20	-
	21	-
	22	-

Instrument designs with non-adjustable measuring inserts are not suitable for use in Zone 0.

The minimum neck length is defined as the distance between the lower edge of the connection head and the heat-radiating surface and is to be selected according to the table "instrument classification" of the type examination certificate / operating instructions.

Built-in transmitters have their own approval. The permissible ambient temperature ranges of the built-in transmitters can be taken from the corresponding transmitter approval.

# Electrical connection

## Connection head JS

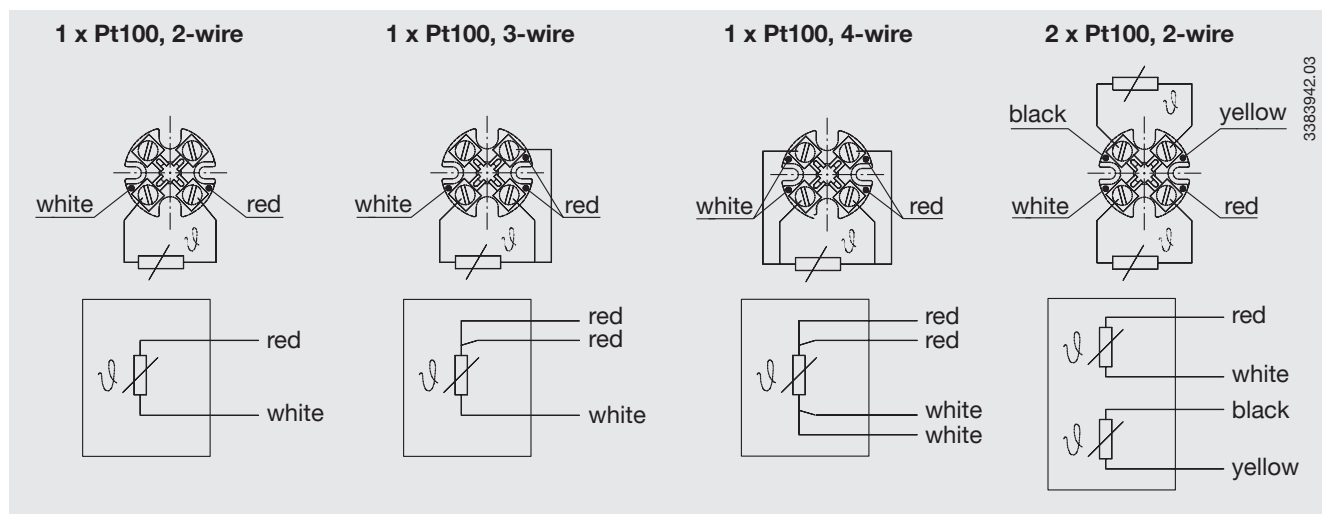

Modifications may take place and materials specified may be replaced by others without prior notice. Specifications and dimensions given in this leaflet represent the state of engineering at the time of printing.



**WIKAI Alexander Wiegand GmbH & Co. KG**  
 Alexander-Wiegand-Straße 30  
 63911 Klingenberg/Germany  
 Tel. (+49) 9372/132-0  
 Fax (+49) 9372/132-406  
 E-mail info@wika.de  
 www.wika.de