

Process resistance thermometer Model TR12-B, for additional thermowell Model TR12-M, basis module

WIKA data sheet TE 60.17



Applications

- Chemical industry
- Petrochemical industry
- Offshore
- Plant and vessel construction

Special features

- For many variants of temperature transmitters with field transmitter
- For mounting in all standard thermowell designs
- Spring-loaded measuring insert (replaceable)
- Explosion-protected versions Ex d, Ex i



Fig. left: Process resistance thermometer model TR12-B

Fig. right: Basis module model TR12-M

Description

Resistance thermometers in this series can be combined with a large number of thermowell designs. The replaceable, centrally spring-loaded measuring insert and its extended spring travel enable combination with the widest range of connection head designs.

A wide variety of possible combinations of sensor, connection head, insertion length, neck length, connection to thermowell etc. are available for the thermometers; suitable for any thermowell dimension and any application.

Specifications

Output signal Pt100

Temperature range	Measuring range -200 ... +600 °C		
Measuring element	Pt100 (measuring current: 0.1 ... 1.0 mA)		
Connection method	1 x 2-wire 1 x 3-wire 1 x 4-wire 2 x 2-wire 2 x 3-wire 2 x 4-wire		
Sensor tolerance value ¹⁾ per EN 60751		wire-wound	thin film
	Class B	-200 ... +600 °C	-50 ... +500 °C
	Class A	-100 ... +450 °C	-30 ... +300 °C
	Class AA	-50 ... +250 °C	0 ... +150 °C

Output signal 4 ... 20 mA, HART® protocol, FOUNDATION™ fieldbus and PROFIBUS® PA ²⁾

Transmitter (selectable versions)	model T19	model T24	model T12	model T32	model T53	Models TIF50, TIF52
Data sheet	TE 19.03	TE 24.01	TE 12.03	TE 32.04	TE 53.01	TE 62.01
Output						
■ 4 ... 20 mA	x	x	x	x		x
■ HART® protocol				x		x
■ FOUNDATION™ Fieldbus and PROFIBUS® PA					x	
Connection method						
■ 1 x 3-wire	x	x	x	x	x	x
■ 1 x 4-wire			x	x	x	x
Measurement current	0.8 mA	0.5 mA	0.2 mA	0.3 mA	0.2 mA	0.3 mA

Measuring insert (replaceable)

Material	Stainless steel 1.4571, 316/316L
Diameter	Standard: 3 mm ³⁾ , 6 mm, 8 mm (with sleeve) Option (on request): 1/8 inch ³⁾ (3.17 mm), 1/4 inch (6.35 mm), 3/8 inch (9.53 mm)
Spring travel	approx. 20 mm
Response time (in water, per EN 60751)	t ₅₀ < 10 s t ₉₀ < 20 s (measuring insert diameter 6 mm: The thermowell required for the operation increases the response time depending on the actually thermowell and process parameters.)

Neck tube

Material	Stainless steel 316/316L/316Ti
Thread to the thermowell	G 1/2 B G 3/4 B 1/2 NPT 3/4 NPT M14 x 1.5 M18 x 1.5 M20 x 1.5 M27 x 2
Connection thread to the head	M20 x 1.5, adjustable lock nut M24 x 1.5, adjustable lock nut 1/2 NPT 3/4 NPT
Neck length	min. 150 mm, standard neck length 200 mm 250 mm Other neck lengths on request

Use resistance thermometers with shielded cable, and ground the shield on at least one end of the lead, if the lines are longer than 30 m or leave the building. For a correct determination of the overall measuring error, consider both sensor and transmitter measuring deviations.

- 1) For detailed specifications for Pt100 sensors, see Technical Information IN 00.17 at www.wika.com
- 2) Protect temperature transmitter therefore from temperatures over 85 °C.
- 3) Not at 2 x 4-wire connection method

Ambient conditions

Ambient and storage temperature	{-50} -40 ... +80 °C
Ingress protection	IP 65 per IEC 529/EN 60529 The indicated ingress protection only applies for TR12-B with corresponding thermowell, connection head, cable gland and appropriate cable dimensions
Vibration resistance	6 g peak-to-peak, wire-wound or thin film measuring resistor (standard) 20 g peak-to-peak, wire-wound or thin film measuring resistor (option) 50 g peak-to-peak, thin film measuring resistor (option)

{ } Items in curved brackets are optional extras

TR12 components

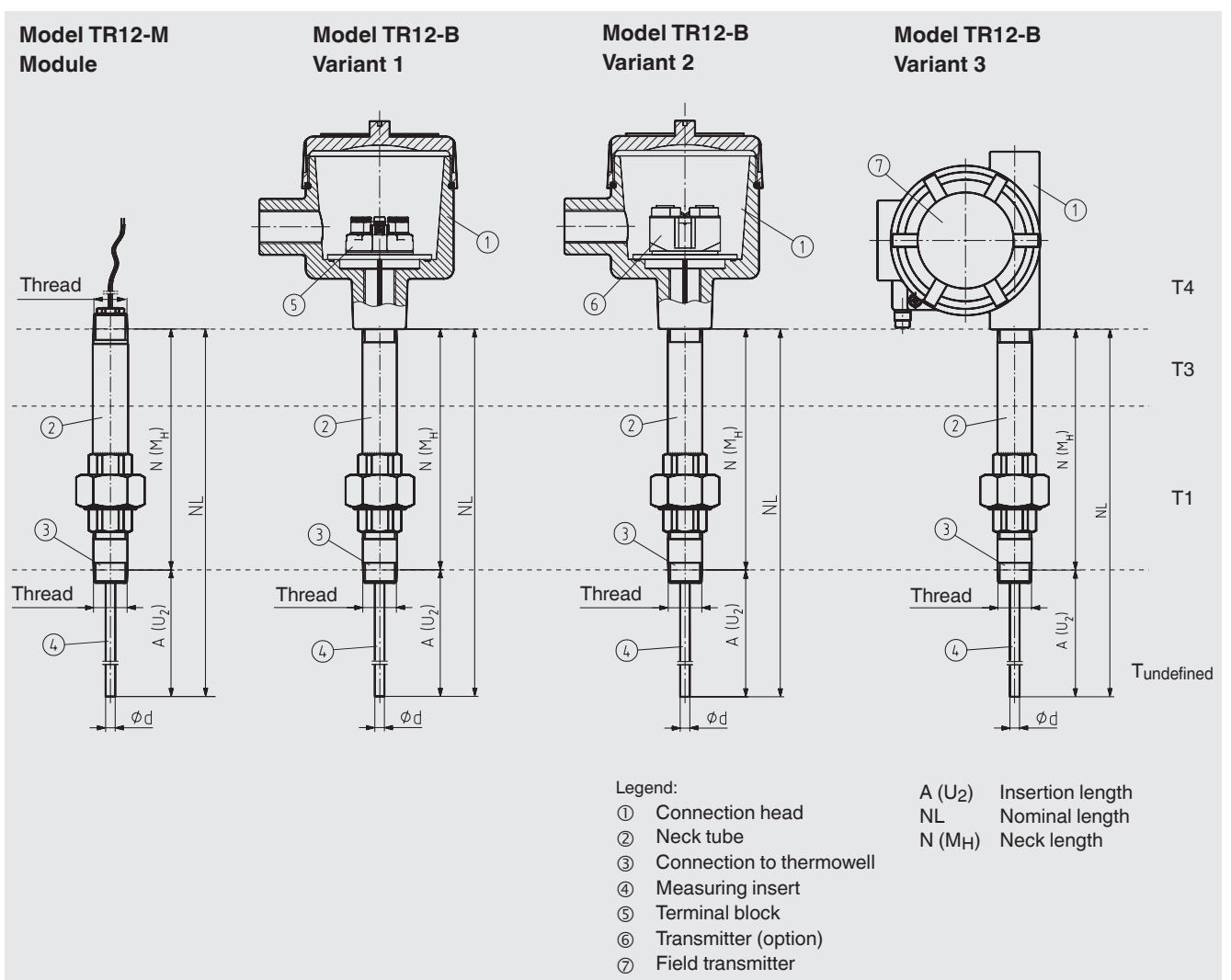

Neck tube versions

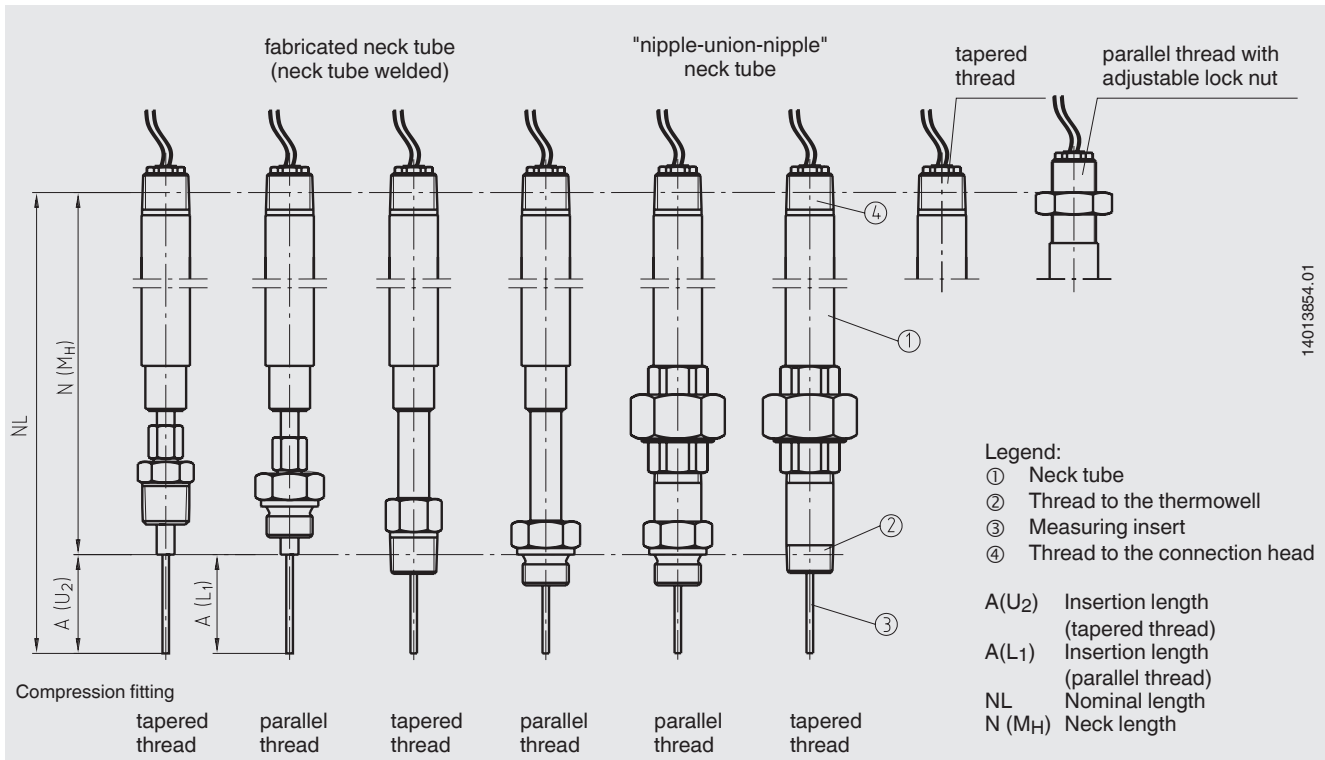

Measuring insert

The exchangeable measuring insert is made of a vibration-resistant sheathed measuring cable (MI cable).

The diameter of the measuring insert should be approx. 1 mm smaller than the bore diameter of the thermowell. Gaps of more than 0.5 mm between thermowell and the measuring insert will have a negative effect on the heat transfer, and they will result in unfavourable response behaviour from the thermometer.

When fitting the measuring insert into a thermowell, it is very important to determine the correct insertion length (= thermowell length for bottom thicknesses of ≤ 5.5 mm). The measuring insert should be spring-loaded (spring travel: 0 ... 20 mm) in order to ensure that it presses against the bottom of the thermowell.

Neck tube

The neck tube is screwed into the connection head or the case. The neck length depends on the intended use. Usually an isolation is bridged by the neck tube. Also, in many cases, the neck tube serves as a cooling extension between the connection head and the medium, in order to protect any possible built-in transmitter from high medium temperatures.

In the Ex d version the flameproof joint is integrated in the neck tube.

Thermowell selection

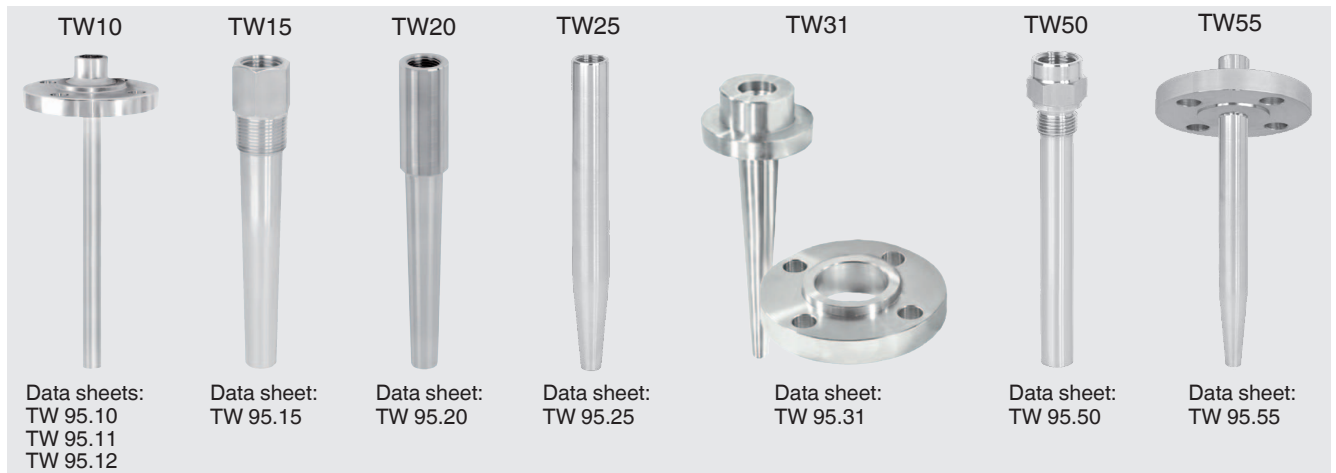

Special thermowells on request

Connection head

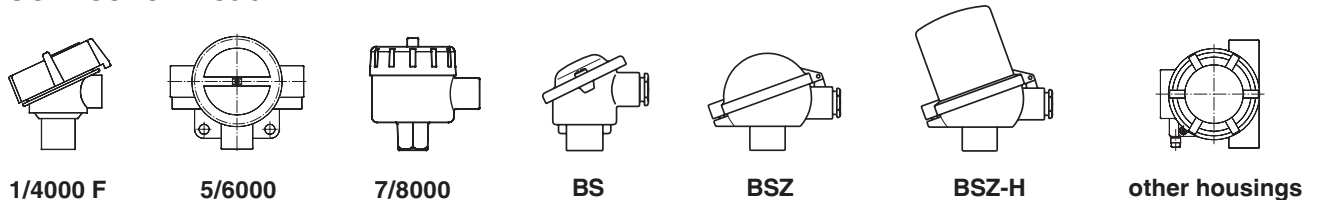

Model	Material	Cable entry	Ingress protection	Explosion protection	Cap	Surface finish
1/4000 F	Aluminium	½ NPT, ¾ NPT, M20 x 1.5	IP 65 ¹⁾	without, Ex i, Ex d	Screw cover	blue, painted ²⁾
1/4000 F	Stainless steel	½ NPT, ¾ NPT, M20 x 1.5	IP 65 ¹⁾	without, Ex i, Ex d	Screw cover	blank
5/6000	Aluminium	½ NPT, ¾ NPT, M20 x 1.5	IP 65 ¹⁾	without, Ex i, Ex d	Screw cover	blue, painted ²⁾
7/8000	Aluminium	½ NPT, ¾ NPT, M20 x 1.5	IP 65 ¹⁾	without, Ex i, Ex d	Screw cover	blue, painted ²⁾
7/8000	Stainless steel	½ NPT, ¾ NPT, M20 x 1.5	IP 65 ¹⁾	without, Ex i, Ex d	Screw cover	blank
BS	Aluminium	½ NPT, M20 x 1.5	IP 65 ¹⁾	without, Ex i	Cap with 2 screws	blue, painted ²⁾
BSZ	Aluminium	½ NPT, M20 x 1.5	IP 65 ¹⁾	without, Ex i	Flip-top with cylinder head screw	blue, painted ²⁾
BSZ-H	Aluminium	½ NPT, M20 x 1.5	IP 65 ¹⁾	without, Ex i	Flip-top with cylinder head screw	blue, painted ²⁾

1) The indicated ingress protection only applies for TR12-B with corresponding cable gland, appropriate cable dimensions and mounted thermowell.
 2) RAL5022

Field temperature transmitter with digital display (option)

Field temperature transmitter models TIF50, TIF52

As an alternative to the standard connection head the thermometer can be fitted with an optional models TIF50 or TIF52 field temperature transmitter.

The field temperature transmitter comprises a 4 ... 20 mA/ HART® protocol output and is equipped with an LCD indication module.

Model TIF50: HART® slave

Model TIF52: HART® master



Field temperature transmitter models TIF50, TIF52

Transmitter (option)

As an option, WIKA transmitters can be installed in the TR12-B connection head.

Model	Description	Explosion protection	Data sheet
T19	Analogue transmitter, configurable	without	TE 19.03
T24	Analogue transmitter, PC configurable	optional	TE 24.01
T12	Digital transmitter, PC configurable	optional	TE 12.03
T32	Digital transmitter, HART® protocol	optional	TE 32.04
T53	Digital transmitter FOUNDATION™ Fieldbus and PROFIBUS® PA	standard	TE 53.01
TIF50	Digital field temperature transmitter, HART® protocol (slave)	optional	TE 62.01
TIF52	Digital field temperature transmitter, HART® protocol (master)	optional	TE 62.01

Other transmitters on request

Explosion protection

For application in hazardous areas, corresponding versions are available.

Intrinsic safety

The instruments comply with the requirements of 94/9/EC (ATEX) directive for gas.

Flameproof enclosure

These instruments comply with the requirements of 94/9/EC (ATEX) directive or IECEx for gas.

The classification/suitability of the instrument (permissible power P_{max} as well as the permissible ambient temperature) for the respective category can be seen on the EC type-examination certificate or on the IECEx certificate and in the operating instructions.

Built-in transmitters have their own EC type-examination certificate. The permissible ambient temperature ranges of the built-in transmitters can be taken from the corresponding transmitter approval.

Functional safety (option)

In safety-critical applications, the entire measuring chain must be taken into consideration in terms of the safety parameters. The SIL classification allows the assessment of the risk reduction reached by the safety installations.

Selected TR12 process resistance thermometers in combination with an appropriate temperature transmitter (e.g. model T32.1S) are suitable as sensors for safety functions up to SIL-2.

Matched thermowells allow easy dismounting of the measuring insert for calibration. The optimally tuned measuring point consists of a thermowell, a TR12 thermometer and a T32.1S transmitter developed in accordance with IEC 61508. Thus, the measuring point provides maximum reliability and a long service life.

Electrical connection

(Colour code per IEC 60751)

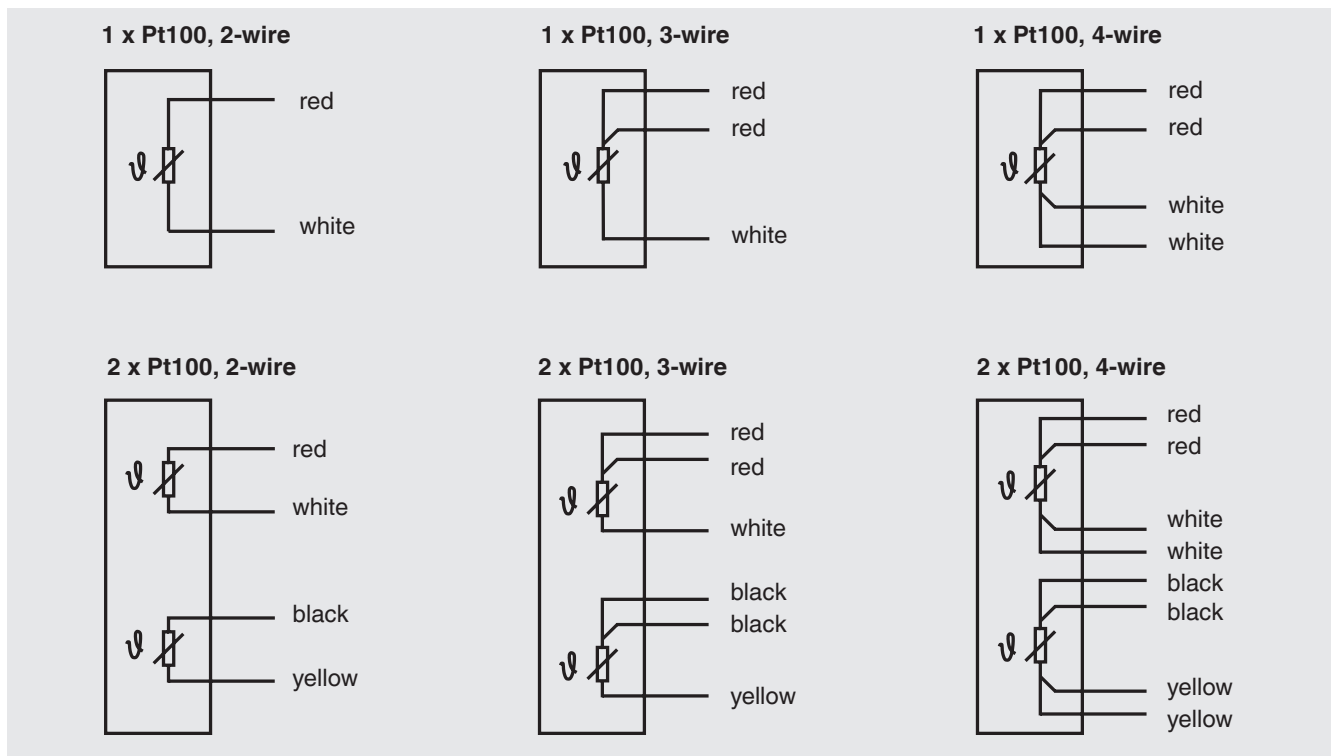

For the electrical connections of built-in temperature transmitters see the corresponding data sheets or operating instructions.

Ordering information

Model / Explosion protection / Ignition protection type / Sensor / Sensor specification / Thermometer operating range / Terminal box / Thread size at the cable entry / Cable entry / Transmitter / Neck tube version / Connection to housing, connection head / Connection to thermowell / Neck tube length N(MH) / Insertion length A / Measuring insert / Options

© 2011 WIKA Alexander Wiegand SE & Co. KG, all rights reserved.
The specifications given in this document represent the state of engineering at the time of publishing.
We reserve the right to make modifications to the specifications and materials.

